

## پلاگ فن

### مشخصات اصلی

محدوده هوادهی: 500-13500CMF  
پروانه بکوارد از فولاد ST-37 ساخته شده است.

### مزیت پلاگ فن ها:

صرفه جویی در مصرف انرژی  
اشغال فضای کم تر  
هزینه مناسب  
تعمیر و نگهداری راحت تر

### مشخصات فنی

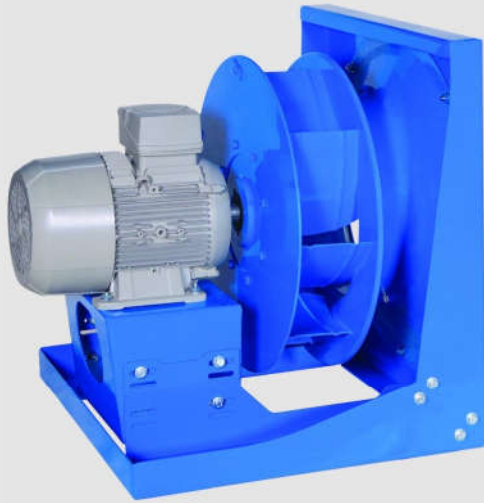

Type	280	315	355	400	450	500	560	630	710	800	900	1000
Max Air Flow at Best Efficiency (CFM)	2200	2500	2900	3500	4300	5600	7000	8000	10500	13500	16000	18000
Static Pressure range (In.w.g)	0.4-6	0.4-6	0.4-6	0.4-6	0.4-6	0.4-6	0.4-6	0.4-6	0.4-6	0.4-6	0.4-6	0.4-6
Sound Level (db)	58-85	58-85	58-85	58-85	58-85	58-85	64-90	64-90	64-90	64-90	65-95	65-95
Fan Weight without motor (Kg)	18	25	32	37	49	56	96	104	141	145	305	320

### مشخصات ابعادی

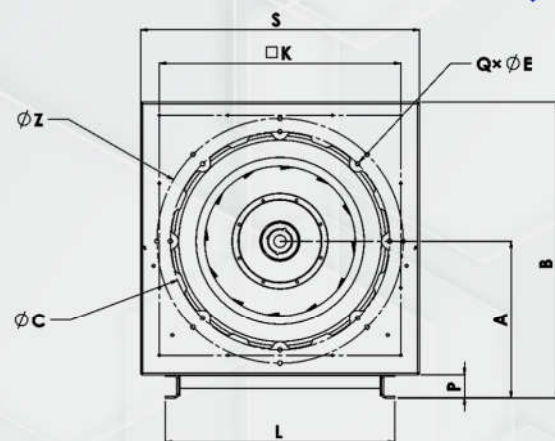
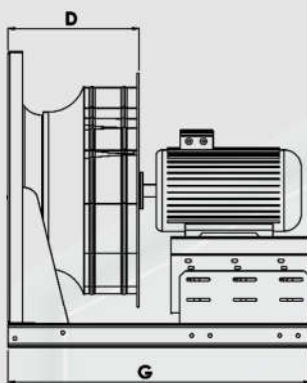

MODEL	motor frame size	F	G
710 _ 800	132	383	910
	160		
	180	443	995
	225	445	1040
900 _ 1000	160	468	1070
	180		
	200	508	1150
	225		

MODEL	A	B	Ø C1	Ø C2	E	K	L	H	J	Y	P	Q	S
710 - 800	543	1023	755	847	65	831	790	750	360	235.5	80	8	960
900 - 1000	674	1264	945	1050	70	1037	1040	1000	270	383.5	100	8	1180

MODEL	motorframe size	F	G	M	M1
250 280 315	71	342	450	40	70
	80				
	90				
	100				
	112				
355 400	80	385	495	40	70
	90				
	100				
	112	675	40		
	132				
160	540				
450 500	80	435	560	45	85
	90				
	100				
	112				
	132				
160	585				
560 630	100	652	825	60	60
	112				
	132				
	160				
	180				
200	790	920			

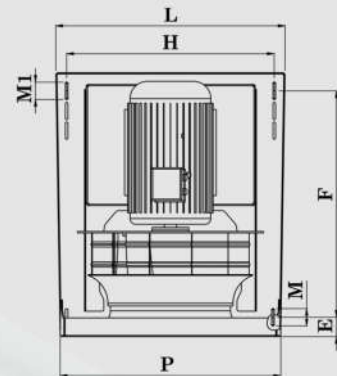
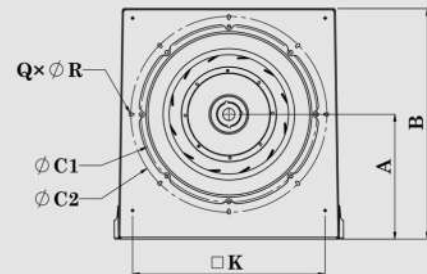
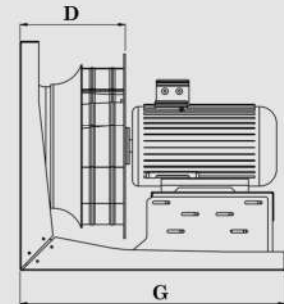

MODEL	A	B	H	E	K	L	P	phi C1	phi C2	Q	phi R
250	215	426	360	52	352	415	405	280	-	6	7.5
280								325	10		
315								354			
355	270	510	460	58	434	513	492	395	438	8	8.5
400											
450											
500	335	630	560	60	537	613	600	490	545		
560	433	800	720	67	668	795	765	610	680	12	
630											